

DONE



**PARTS CATALOG FOR
KELLEY BACKHOES**

Models B30FJ, BS30JS

NOVEMBER 1, 1989

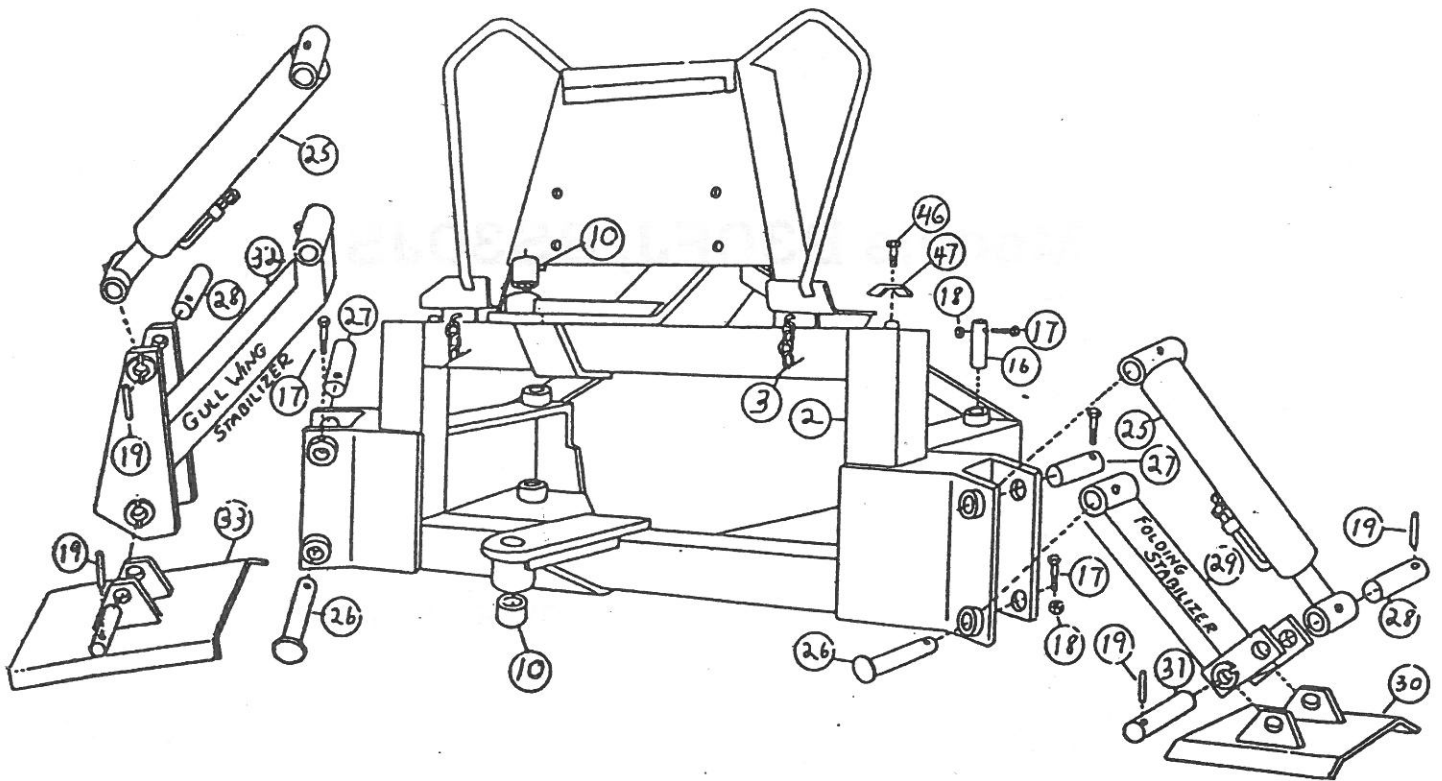
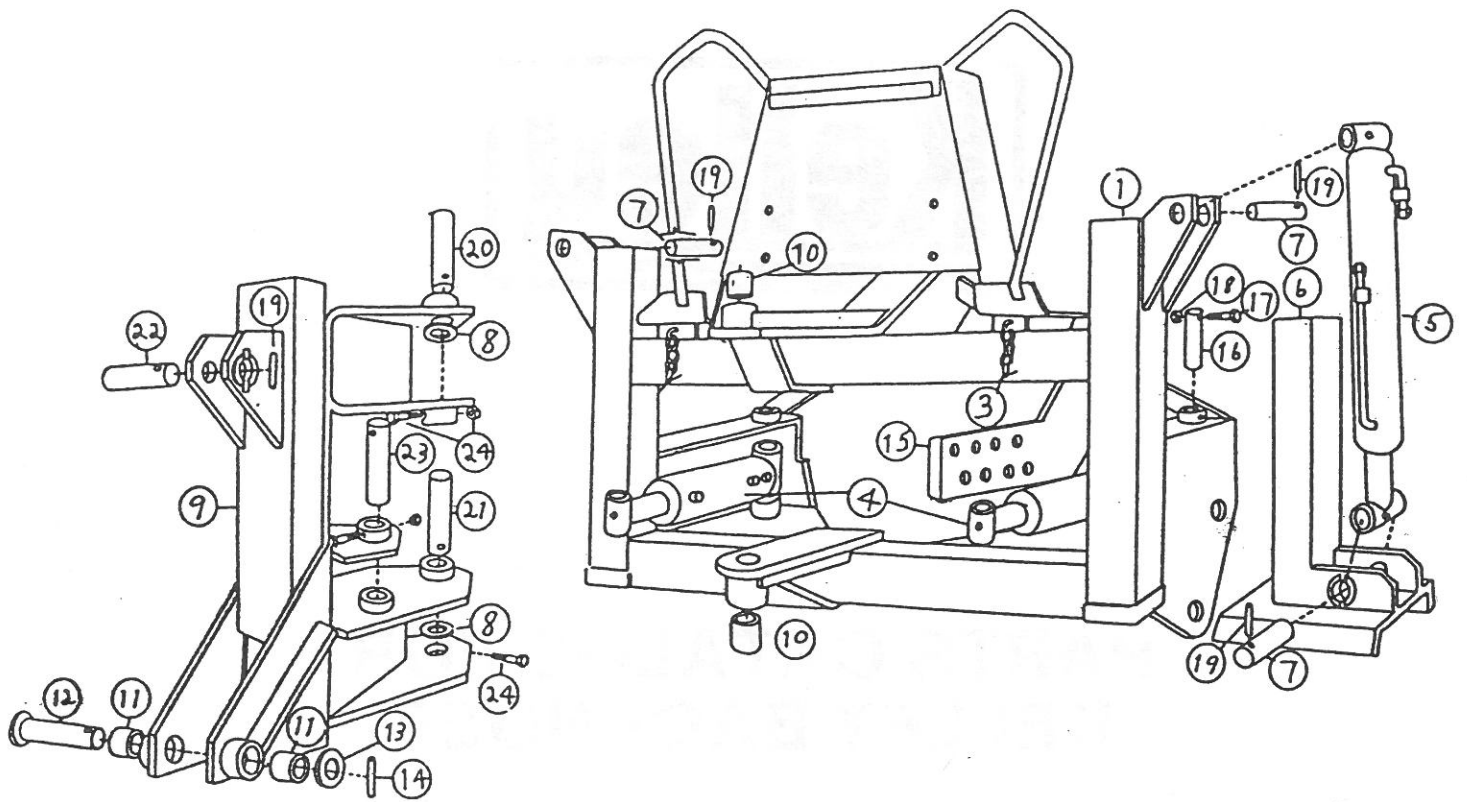

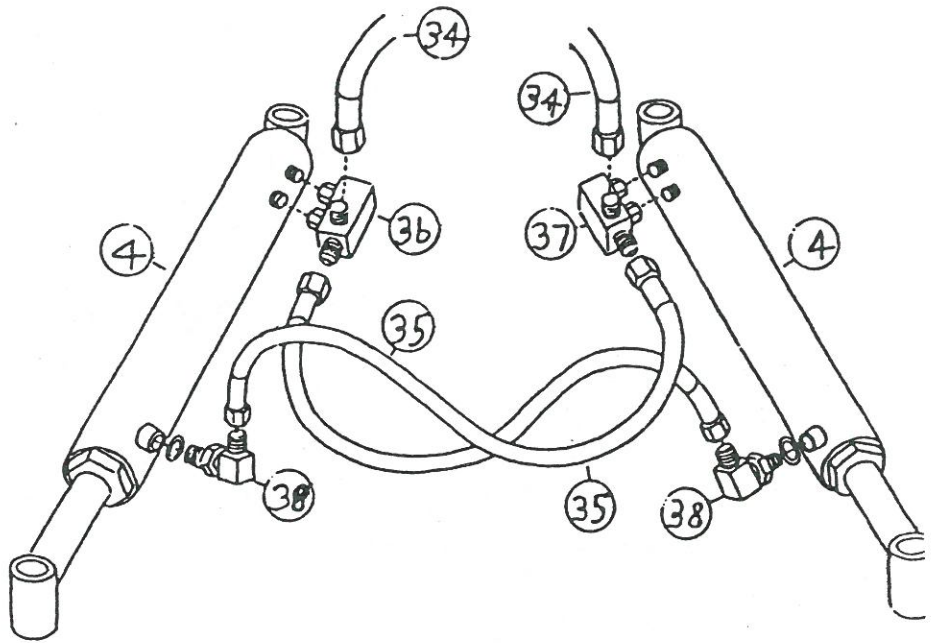
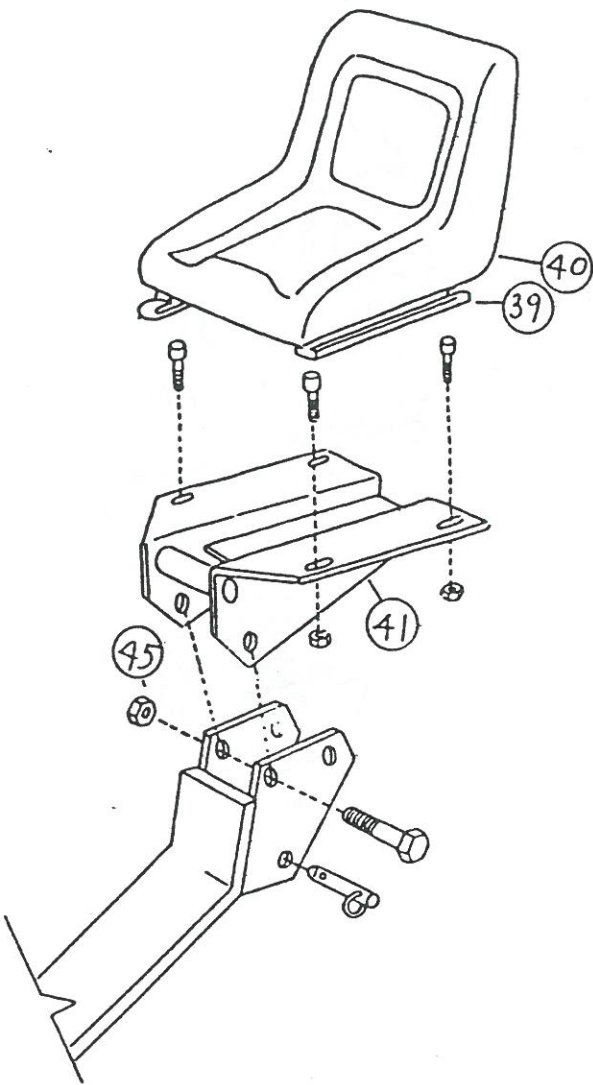

MAIN FRAME, STABILIZERS, SEAT AND SWING

Ill. No.	Qty.	Part No.	Description	Ill. No.	Qty.	Part No.	Description
1	1	BMF11116	Main Frame Weld Assembly, Vertical Stabilizer	30	2	BMF11126	Pad, Stabilizer
2	1	BMF11117	Main Frame Weld Assembly, Folding Stabilizer	31	2	SPN10463	Pin, 1"x5-3/4" (5/16" Hole)
NI	1	BMF10943	Main Frame Weld Assembly, Skid Steer	32	2	BMF10276	Gull Wing Stabilizer, R.H. & L.H.
3	1	BMS350	Chain Safety, 46"	33	2	BMF10777	Gull Wing Stabilizer Pad
4	2	BCY302	Cylinder, 2-1/2"x10" Swing	34	2	SHO11120	Hose, 4P-6JFS-6JFS-23" R.H. Swing
5	2	BCY305	Cylinder, 2-1/2"x16" Vertical Stabilizer	35	2	SHO10082	Hose, 4P-6JFS-6JFS-26" Swing Cylinder
6	1	BMF11118	Stabilizer L.H., Vertical	36	1	SFT314	Manifold Cushion Valve, R.H.
NI	1	BMF11119	Stabilizer R.H., Vertical	37	1	SFT313	Manifold Cushion Valve, L.H.
7	2	SPN117	Pin, 1"x4-1/4" (5/16" Hole)	38	1	SFT312	Elbow, 85°x6 O'Ring
8	2	SWS10961	Washer, 1-1/4" Heat Treated Machine	39	2	BMS232	Seat Adjuster
9	1	BMF10944	Swing Mast Weld Assembly	40	1	BMS215	Seat Assembly, Complete
10	2	SFT10978	Bushing, 1-1/4"IDx1-1/2" Steel W/Groove	41	1	BMS10186	Seat, Base
11	2	SFT10950	Bushing, 1-1/4"IDx1" Steel W/Groove	42	1	SPN10188	Pin, Fast 1/2"x4-1/2" Fast
12	1	SPN10945	Pin, 1-1/4"x8-3/4" W/Washer (3/8" Hole)	43	1	BMS231	Seat
13	1	SWS10952	Washer, 1-1/4" ID	44	1	SBT2050	Capscrew, 1/2"x3-1/2"
14	1	SPN10946	Pin, 3/8"x2-1/2" Roll	45	1	SNT2060	Locknut, 1/2"
15	1	BMT326	Third Point Link	46	2	SBT2022	Capscrew, 3/8"x1"
NI	1	SFT327	Bushing, Category II to I	47	2	LMT2008	Clamp, Steel Oil Line
16	2	SPN10457	Pin, 1"x6" (5/16" Hole)	NI	2	SBT169	Capscrew, 7/8"x2-1/2" NF Grade 5
17	4	SBT10795	Capscrew, 5/16"x2"	NI	2	SWS245	Lockwasher, 7/8" Star
18	4	SNT2018	Nut, 5/16" NC	NI	2	SNT393	Nut, 7/8" NF
19	1	SPN11718	Pin, Roll 5/16"x2" W/3/16" Insert Pin	NI	2	SWS2033	Lockwasher, 3/8" Star
20	1	SPN10947	Pin, 1-1/4"x5-5/8" Top (3/8" Hole)	NI	2	SWS2019	Lockwasher, 5/16" Star
21	1	SPN331	Pin, 1-1/4"x5-1/8" Lower (3/8" Hole)	NI	2	SPN10453	Pin, 7/8"x4-3/8" W/Washer (1/2" Hole)
22	1	SPN332	Pin, 1"x3"	NI	2	SPN10455	Pin, 7/8"x5-7/8" W/Washer (1/2" Hole)
23	2	SPN10042	Pin, 1"x4-3/8" (5/16" Hole)	NI	1	SFT2012	Drive Zerk, 5/16"
24	2	SBT10796	Capscrew, 3/8"x2-1/2" NC	NI	1	SFT11612	Threaded Zerk
24	2	SNT2031	Nut, 3/8" NC	NI	2	BOL11728	Steel Oil Line, Folding Stabilizer
25	2	BCY11632	Cylinder, 2-1/2"x13" Folding & Gull Wing				
26	2	SPN10949	Pin, 1"x6-5/8" W/Washer (5/16" Hole)				
27	2	SPN10975	Pin, 1"x6-5/8" (5/16" Hole)				
28	2-4	SPN11013	Pin, 1"x5" (5/16" Hole)				
29	1	BMF11125	Stabilizer, L.H. & R.H. Folding				

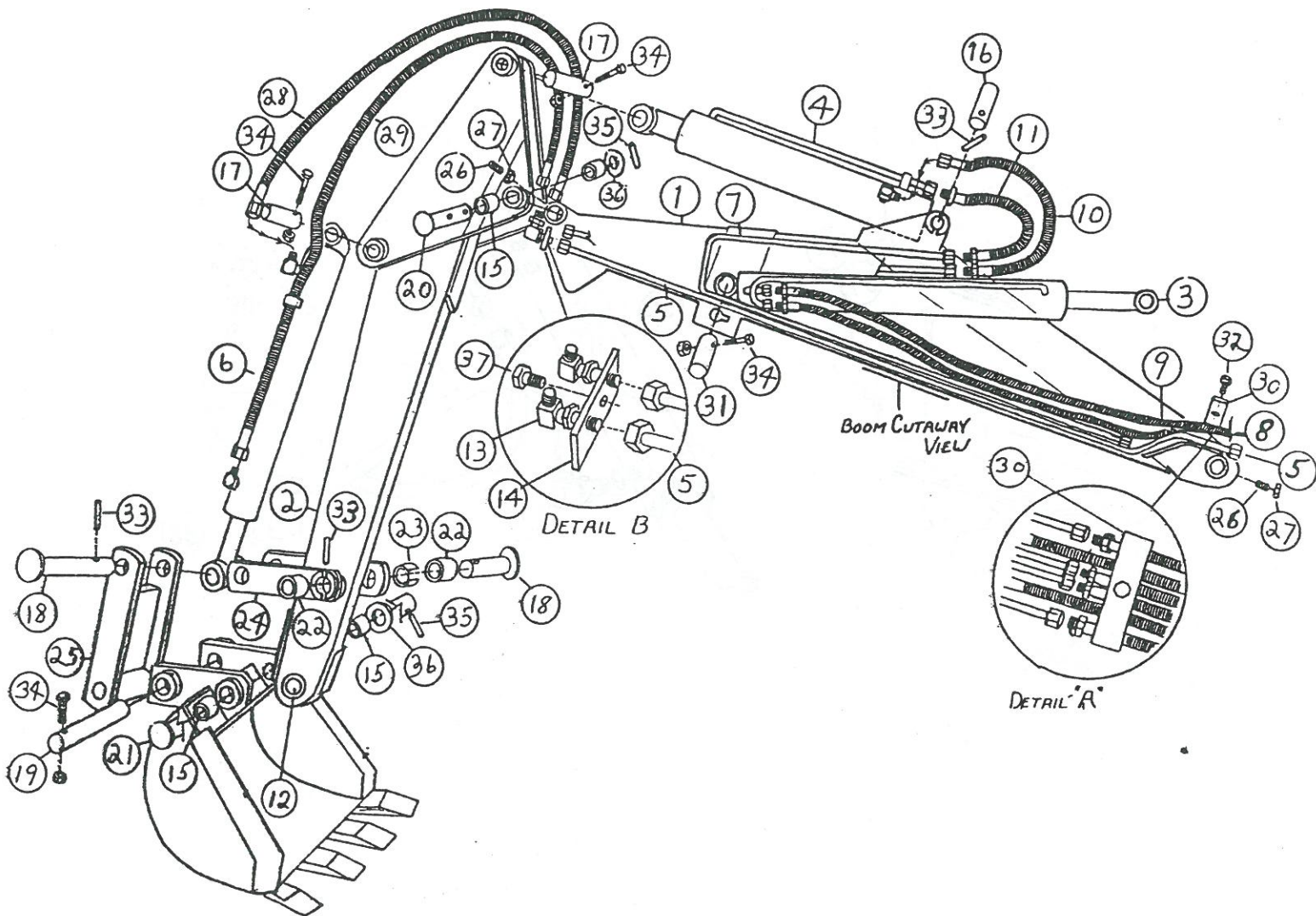

BOOM, DIPPER, STICK AND BUCKET

Ill. No.	Qty.	Part No.	Description
1	1	BMF10954	Boom Weld Assembly
2	1	BMF10955	Dipper Stick Assembly
3	1	BCY303	Cylinder, 2-1/2"x26" Boom
4	1	BCY304	Cylinder, 2-1/2"x20" Dipper
5	2	BOL353	Oil Line Steel, Bucket
6	1	BCY11631	Cylinder, 2-1/2"x20" Bucket
7	2	BOL352	Oil Line Steel, Dipper U-Pipe
8	1	SHO10925	Hose, 6P-6JFS-6JM-82" Boom Raise
9	1	SHO10945	Hose, 4P-6JFS-6JM-84" Boom Lower
10	1	SHO10043	Hose, 6P-6JM-6JFS-15" Dipper In
11	1	SHO10960	Hose, 4P-6JM-6JM-15" Dipper Out
12	2	SMS11723	Bushing, 1"IDx1-1/4"ODx1-3/8"
13	2	SFT311	Fitting, 833Bx6 Bulkhead
14	1	BMT325	Plate, Bulkhead Elbow Retaining
15	4	SFT10950	Bushing, 1-1/4"IDx1" Steel
16	1	SPN118	Pin, 1"x5-3/4" (5/16" Hole)
17	2	SPN10463	Pin, 1"x5-3/4" (5/16" Hole)
18	2	SPN10460	Pin, 1"x5-1/2" W/Washer
19	1	SPN10975	Pin, 1"x6-5/8"
20	1	SPN10976	Pin, 1-1/4"x8-1/4" W/Washer

Ill. No.	Qty.	Part No.	Description
21	1	SPN10957	Pin, 1-1/4"x7-3/8"
22	2	SFT10979	Bushing, 1"IDx1" Steel
23	1	SFT10958	Bushing, Steel Spacer
24	2	BMF10465	Link, Cylinder RH & LH
25	1	BMF10467	Link Assembly, Bucket
26	2	SBT10959	Ste Screw, 3/8"x1" Hollow
27	2	SNT10081	Jam Nut, 3/8"
28	1	SHO12496	HOSE, 6P-6JFS-6JFS-28"
29	1	SHO12497	HOSE, 4P-6JFS-6JFS-48"
30	2	SCL324	Hose Clamp, 1"x3-1/2"
31	1	SPN10458	Pin, 1"x7" (5/16" Hole)
32	1	SBT10796	Capscrew, 3/8"x2-1/2"
33	2	SPN10530	Pin, 5/16" x 2" Roll
34	3	SPN10795	Capscrew, 5/16"x2" W/Nut
35	2	SPN10946	Pin, 3/8"x2-1/2" Roll
36	2	SWS10952	Washer, 1-1/4"ID
37	1	SBT10502	Metal Screw 1/4"x3/4"
NI		SFT2012	Drive Zerk, 5/16"
NI		SFT11612	Threaded, Zerk
NI	1	SBT2021	Capscrew, 3/8"x3/4"

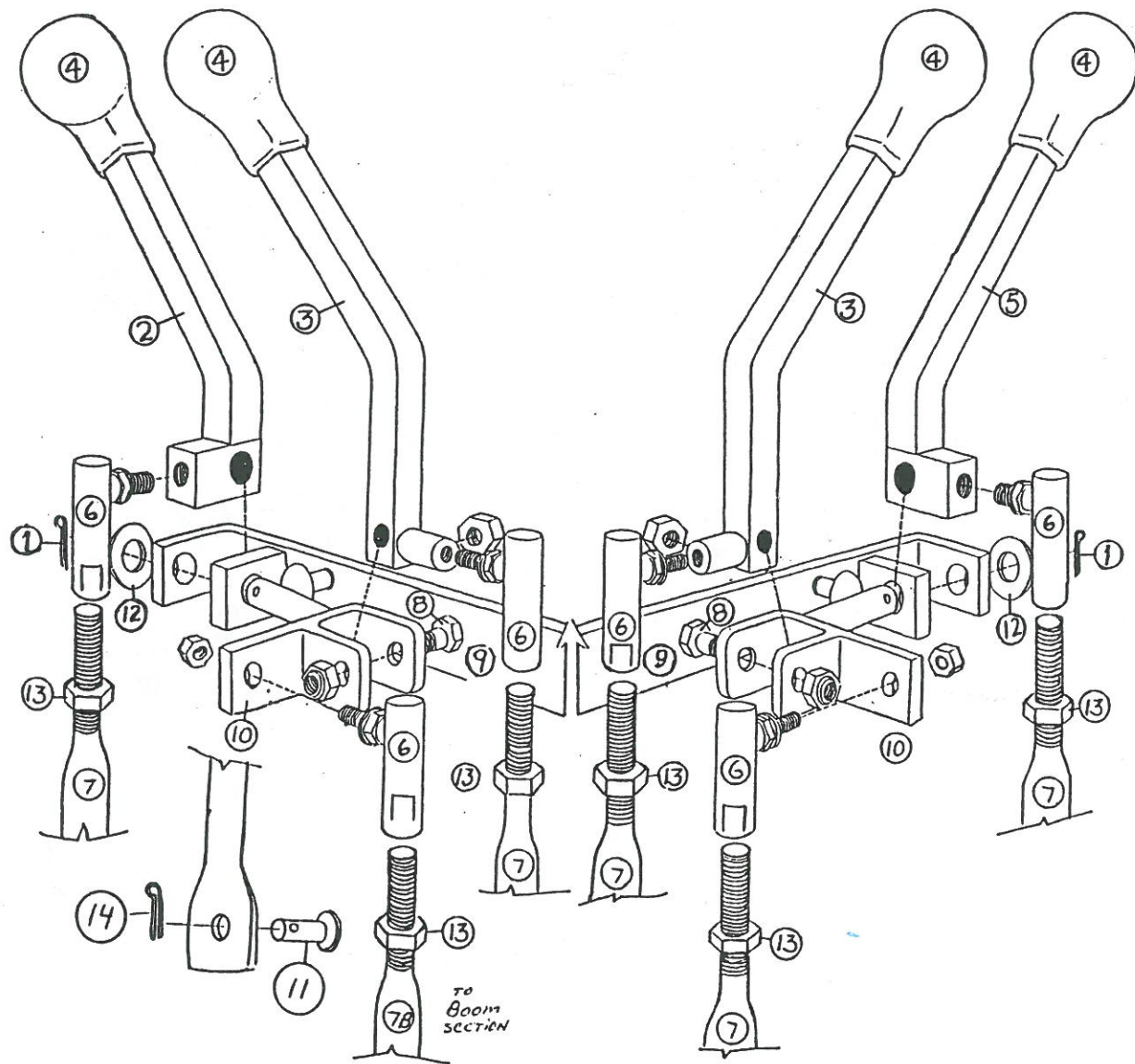

VALVE CONTROLS

ILL NO.	QTY.	PART NO.	DESCRIPTION
1	2	SPN2113	Pin, 1/8" x 1" Cotter
2	1	BMS10054	Control Handle, Stabilizer RH
3	2	BMS10053	Control Handle, Dipper/Bucket/Boom/Swing
4	6	SMS10030	Handle Grip
5	1	BMS10052	Control Handle, Stabilizer LH
6	6	BMS12595	Ball Joint Connector
7	5	BMS12596	Control Rod, 6" for all except boom section
7B	1	BMS12597	Control Rod 5" for boom section
8	2	SMS10057	Lever Bolt with Locknut
9	1	BMS10058	Control Bracket
10	2	BMS10059	Control Pivot Bracket Assembly
11	6	SPN10060	Control Rod Pin, 1/4" x 3/4"
12	2	SWS2112	Washer, 1/2" S.A.E.
13	6	SNT11382	Jam Nut 5/16" NF
14	6	SPN297	Pin, 1/6" x 1" Cotter
NI	1	BMS10062	Control Handle Assembly (Includes all parts except Ill. No.'s 1,7, and 11)

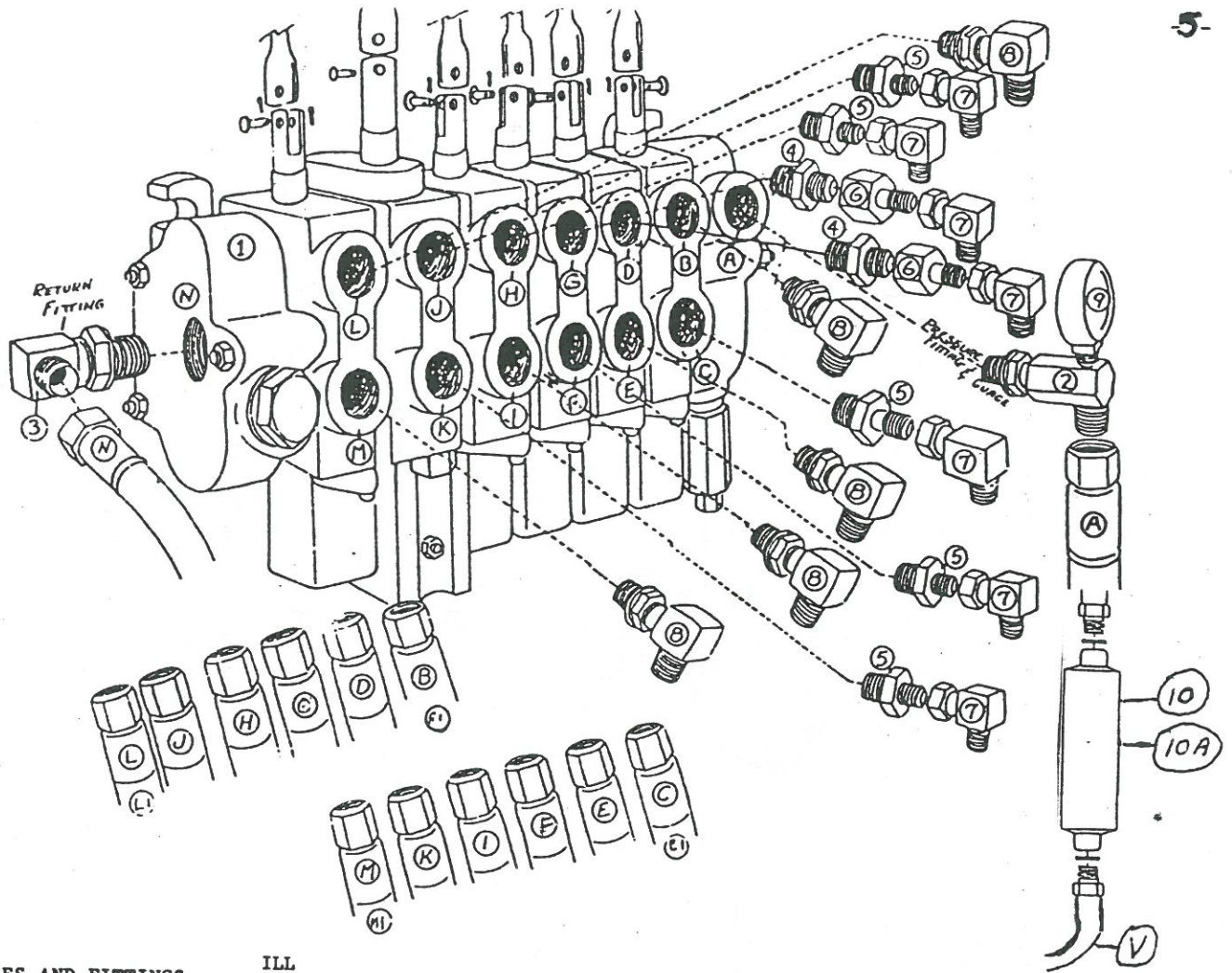

VALVE, HOSES AND FITTINGS

ILL NO.	QTY.	PART NUMBER	DESCRIPTION
1	1	986757	Rexnord Valve W/Float Spool
2	1	SFT250	Fitting, Inlet and Gauge
3	1	SFT310	Return Fitting
4	5	SFT270	Adapter, 8 O'Ring To 8JM
5	5	SFT307	Adapter, 8 O'Ring To 6JM
6	5	SFT10921	Adapter, 8 to 6JIC
6	5	SNT10922	Nut, 8JIC
7	10	SFT308	Elbow, 6FS To 6JM
8	2	SFT306	Elbow, 8 O'Ring to 6JM
9	1	SMS10033	Gauge, Pressure
10	1	SPP11881	Filter Assembly, Complete
10A	1	SPP11977	Filter, Replacement Element Only
V	1	SH011973	Hose, 6P-8-80RB-35" to Filter
A	1	SH011974	Hose, 6P-8JFS-80RB-15" Filter to Inlet
B	1	SH010923	Hose, 6P-6JFS-6JM-29" RH Lower F/Vertical Stabilizer
B1	1	SH011121	Hose, 6P-6JFS-6JM-40" RH Lowering F/Folding Stabilizer
C	1	SH0336	Hose, 6P-6JFS-6JM-28" RH Lift F/Vertical Stabilizer
C1	1	SH0338	Hose, 4P-6JFS-6JM-48" RH Lift F/Folding Stabilizer
D	1	SH0342	Hose, 4P-6JFS-6JM-67" Dipper Stick Out
E	1	SH010069	Hose, 6P-6JFS-6JM-67" Dipper Stick In
F	1	SH010924	Hose, 6P-6JFS-6JM-50" Bucket Curl
G	1	SH0338	Hose, 4P-6JFS-6JM-48" Bucket Uncurl
H	1	SH011120	Hose, 4P-6JFS-6JFS-23" LH Swing Cylinder
I	1	SH011120	Hose, 4P-6JFS-6JFS-23" RH Swing Cylinder
J	1	SH010925	Hose, 6P-6JFS-6JM-82" Boom Lower
K	1	SH0344	Hose, 4P-6JFS-6JM-84" Boom Raise
L	1	SH010923	Hose, 6P-6JFS-6JM-29" LH Lowering F/Vertical Stabilizer
L1	1	SH011121	Hose, 6P-6JFS-6JM-40" LH Lowering F/Folding Stabilizer
M	1	SH0336	Hose, 4P-6JFS-6JM-28" LH Lift F/Vertical Stabilizer
M1	1	SH0338	Hose, 4P-6JFS-6JM-48" LH Lift F/Folding Stabilizer
N	1	SH011123	Hose, 8P-8JFS-8-50"

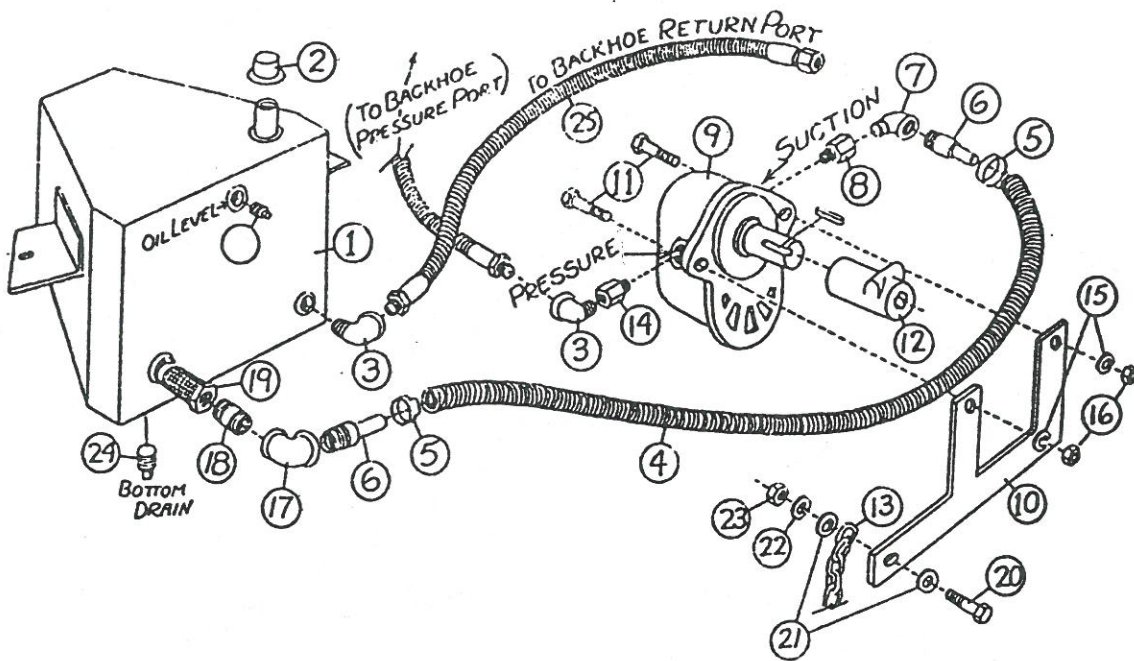

BCP 540RPM PTO INDEPENDENT
HYDRAULIC PUMP SYSTEM

SCP 1000RPM PTO INDEPENDENT
HYDRAULIC PUMP SYSTEM

III. No.	Qty.	Part No.	Description
1	1	BPP11127	Reservoir
2	1	SPP2639	Breather Cap
3	2	SFT2527	Street Elbow, 1/2"
4	1	SHO11140	Hose, 16R-0-0-50" Suction
5	2	SCL2640	Hose Clamp, 1"
6	2	SFT2562	Hose Nipple, 3/4"
7	1	SFT2528	90 Degree Street Elbow, 3/4"
NI	1	SFT2565	Reducer Bushing, 1" to 3/4" (to be placed between items 7 & 8)
8	1	SFT2644	Pump Adapter 6405-20
9	1	SPP6242	Webster 388K81 Pump
10	1	SPP6245	Torque Bar For 388K81 Pump
11	2	SBT2047	Capscrew, 1/2" x 2"
12	1	SPP6243	540, 1-3/8" PTO Pump Drive
13	1	SMS101	Torque Chain, 24"
14	1	SFT2645	Pressure Fitting 5406-20-16
15	2	SWS2061	Lockwasher, 1/2"
16	2	SNT2062	Nut, 1/2"
17	1	SFT10013	90 Degree Reducer Elbow, 3/4" x 1"
18	1	SFT2510	Close Nipple, 1"
19	1	SPP6230	Filter
20	2	SBT2026	Capscrew, 3/8" x 2-1/4"
21	4	SWS2034	Flatwasher, 3/8"
22	2	SWS2033	Lockwasher, 3/8"
23	2	SNT2031	Nut, 3/8"
24	1	SFT2503	Pipe Plug, 1/2"
25	1	SHO11123	Hose, 8P-8-8JFS-50" Return (On Backhoe)
NI	6	SBT2043	Capscrew, 1/2" x 1-1/2"
NI	6	SWS2061	Lockwasher, 1/2" Star
NI	6	SNT2062	Nut, 1/2"
NI	1	BCP10109	Parts Carton (except reservoir)

III. No.	Qty.	Part No.	Description
1	1	BPP11127	Reservoir
2	1	SPP2639	Breather Cap
3	2	SFT2527	Street Elbow, 1/2"
4	1	SHO10015	Hose, 16R-0-0-40" Suction
5	2	SCL2640	Hose Clamp, 1"
6	2	SFT2562	Hose Nipple, 3/4"
7	1	SFT2528	90 Degree Street Elbow, 3/4"
8	1	SFT10104	Adapter, C3296 x 14 x 12
9	1	SPP6213	Webster YC155 Pump
10	1	SPP10105	Torque Bar for YC155 Pump
11	2	SBT2037	Capscrew, 7/16" x 1-3/4"
12	1	SPP10078	Webster YC155 Pump Drive
13	1	SMS101	Torque Chain, 24"
14	1	SFT10106	Fitting, C3296 x 10 x 8
15	2	SWS2042	Lockwasher, 7/16"
16	2	SNT2041	Nut, 7/16"
17	1	SFT10013	90 Degree Elbow, 3/4" x 1"
18	1	SFT2510	Close Nipple, 1"
19	1	SPP6230	Filter
20	2	SBT2026	Capscrew, 3/8" x 2-1/4"
21	4	SWS2034	Flatwasher, 3/8"
22	2	SWS2033	Lockwasher, 3/8"
23	2	SNT2031	Nut, 3/8"
24	1	SFT2503	Pipe Plug, 1/2"
25	1	SHO11123	Hose, 8P-8-8JFS-50" Return (On Backhoe)
NI	4	SBT2043	Capscrew, 1/2" x 1-1/2"
NI	4	SWS2061	Lockwasher, 1/2" Star
NI	4	SNT2062	Nut, 1/2"
NI	1	BCP359	Parts Carton (except reservoir)

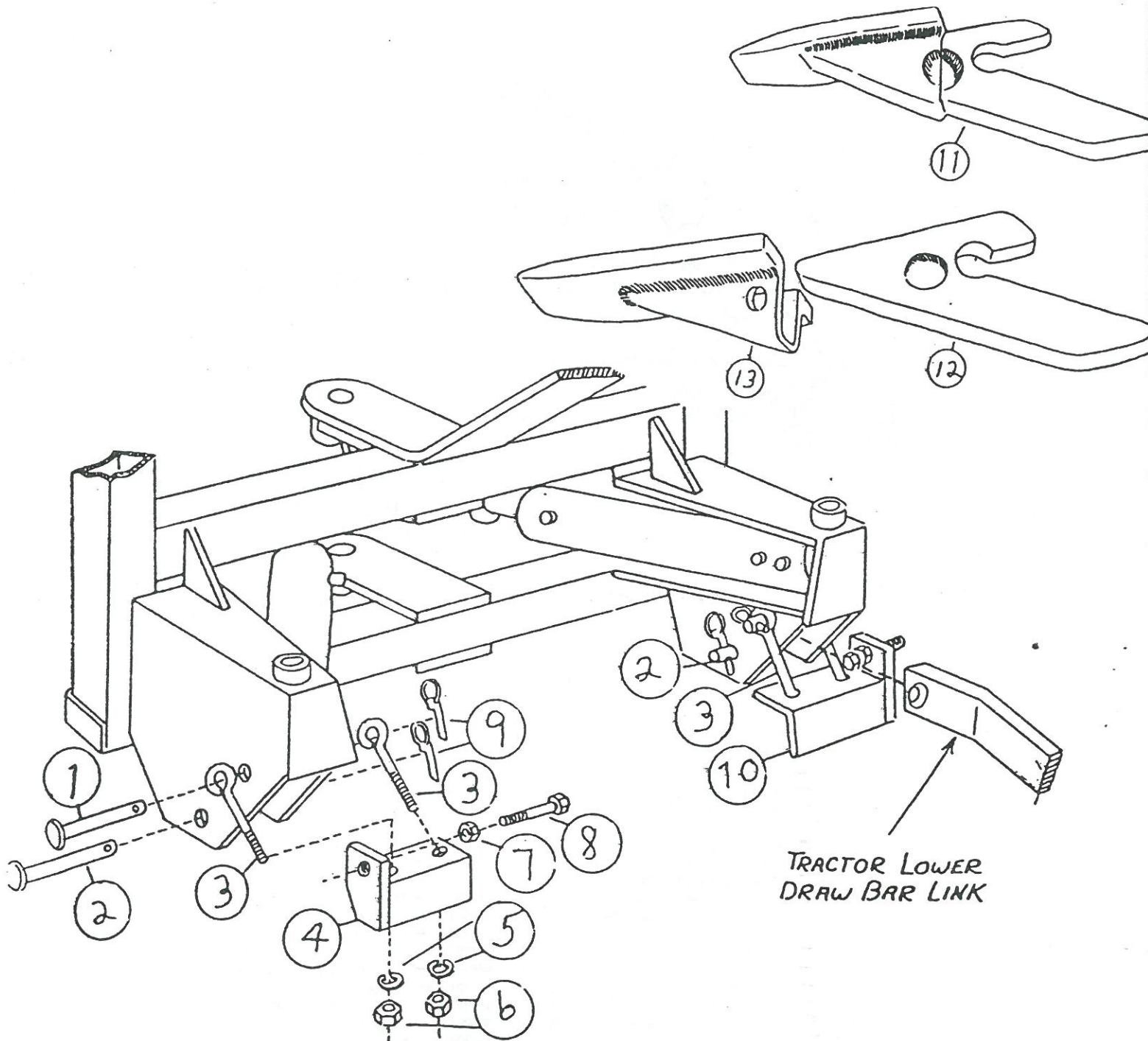

LOWER LINK LOCKS AND BUCKET TEETH

<u>Ill. No.</u>	<u>Qty.</u>	<u>Part No.</u>	<u>Description</u>
1	2	SPN10455	Pin, 7/8"x5-7/8" W/Washer, Link Lock
2	2	SPN10453	Pin, 7/8"x4-3/8" W/Washer, Hitch
3	4	SBT10452	Eyebolt, 3/4"x7"
4	1	BMF10451	Lower Link Lock, L.H.
5	4	SWS2103	Lockwasher, 3/4"
6	4	SNT2102	Nut, 3/4"
7	2	SNT10584	Jam Nut, 3/4"
8	2	SBT10486	Capscrew, 3/4"x3-1/2" W/Extra Threads
9	4	SPN141	Lynch Pin, 7/16"
10	1	BMF10450	Lower Link Lock, R.H.
11		BBK192	Tooth Assembly
12		BBK167	Shank, Tooth
13		BBK168	Point, Tooth

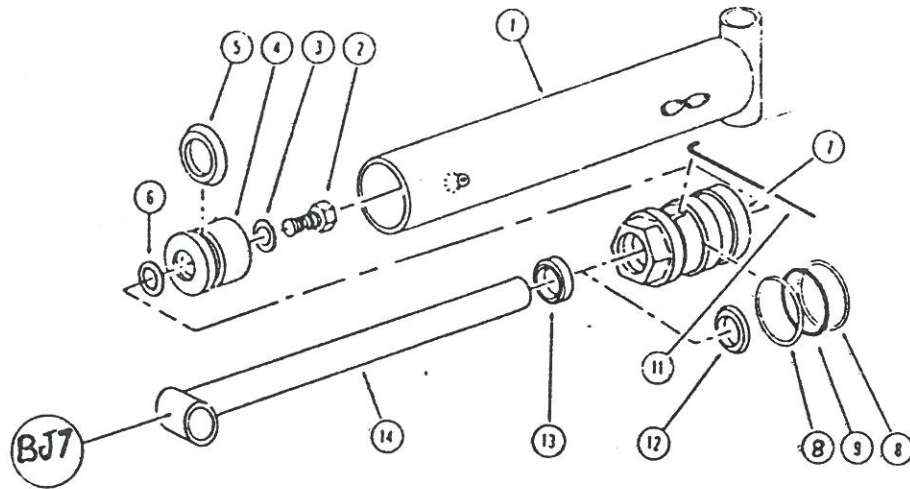

BCY302 SWING CYLINDER, 2-1/2"x10"

Ill. No.	Qty.	Part No.	Description	Ill. No.	Qty.	Part No.	Description
1	1	SCY1083	Barrel Assembly	8*	2	SCY1070	Back-up Rings
2	1	SBT1017	Capscrew, 7/8"	9*	1	SCY1024	O'Ring
3*	1	SCY1018	Dyna Seal, 7/8"	11*	1	SCY1036	Lockwire
4	1	SCY356	Piston	12*	1	SCY1025	Rod Seal
5*	1	SCY1019	Piston Seal	13*	1	SCY1027	Rod Wiper
6*	1	SWS245	Internal Lockwasher	14	1	SCY1082	Rod Assembly
7	1	SCY1023	Cylinder Head	*	1	SCY1030	Seal Kit

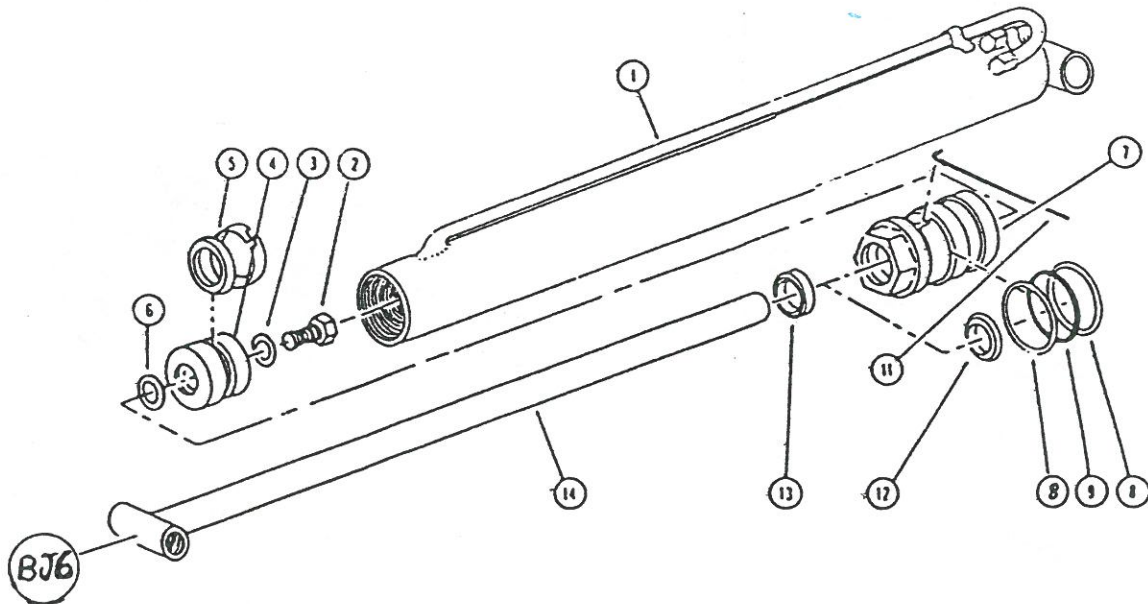

BCY303 BOOM CYLINDER, 2-1/2"x26"

Ill. No.	Qty.	Part No.	Description	Ill. No.	Qty.	Part No.	Description
1	1	SCY1085	Barrel Assembly	8*	2	SCY1070	Back-Up Rings
2	1	SBT1017	Capscrew, 7/8"	9*	1	SCY1024	O'Ring
3*	1	SCY1018	Dyna Seal, 7/8"	11*	1	SCY1036	Lockwire
4	1	SCY1020	Piston	12*	1	SCY1025	Rod Seal
5*	1	SCY1019	Piston Seal	13*	1	SCY1027	Rod Wiper
6*	1	SWS245	Internal Lockwasher	14	1	SCY1084	Rod Assembly
7	1	SCY1023	Cylinder Head	*	1	SCY1030	Seal Kit

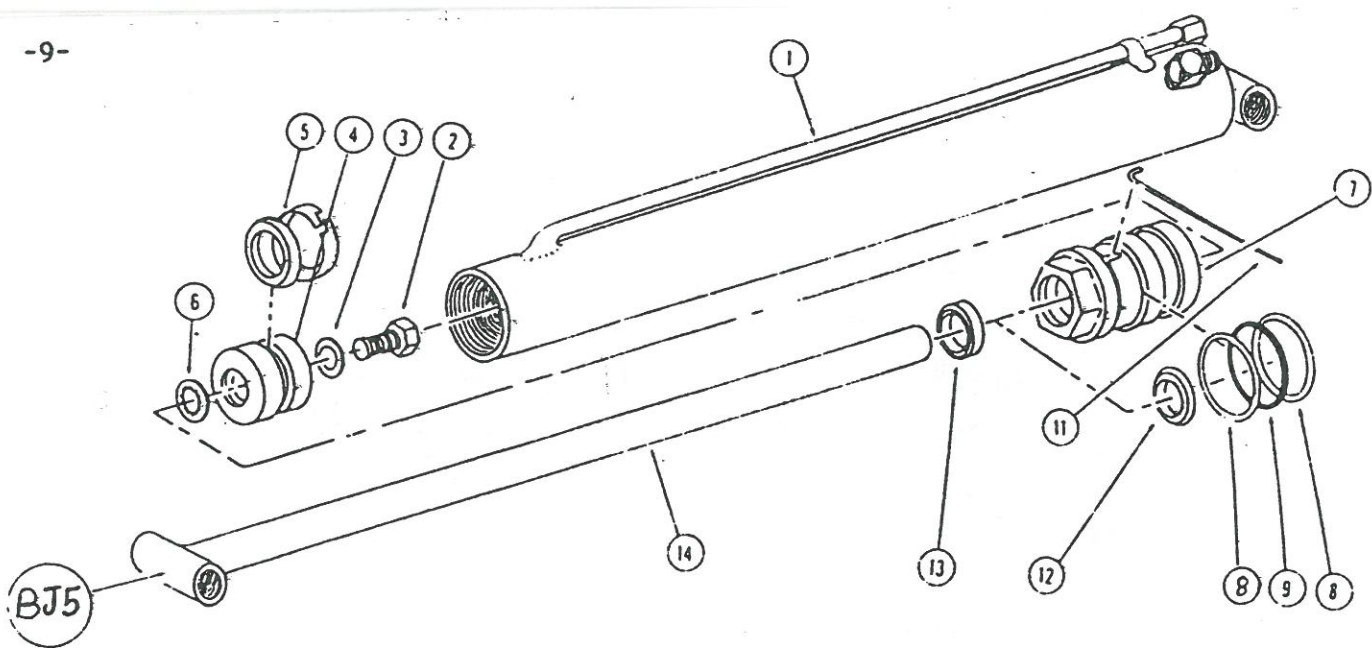

BCY304 DIPPER CYLINDER, 2-1/2"x20"

Ill. No.	Qty.	Part No.	Description	Ill. No.	Qty.	Part No.	Description
1	1	SCY1087	Barrel Assembly	8*	2	SCY1070	Back-Up Ring
2	1	SBT1017	Capscrew, 7/8"	9*	1	SCY1024	O'Ring
3*	1	SCY1018	Dyna Seal, 7/8"	11*	1	SCY1036	Lockwire
4	1	SCY1020	Piston	12*	1	SCY1025	Rod Seal
5*	1	SCY1019	Piston Seal	13*	1	SCY1027	Rod Wiper
6*	1	SWS245	Internal Lockwasher	14	1	SCY1086	Rod Assembly
7	1	SCY1023	Cylinder Head	*	1	SCY1030	Seal Kit

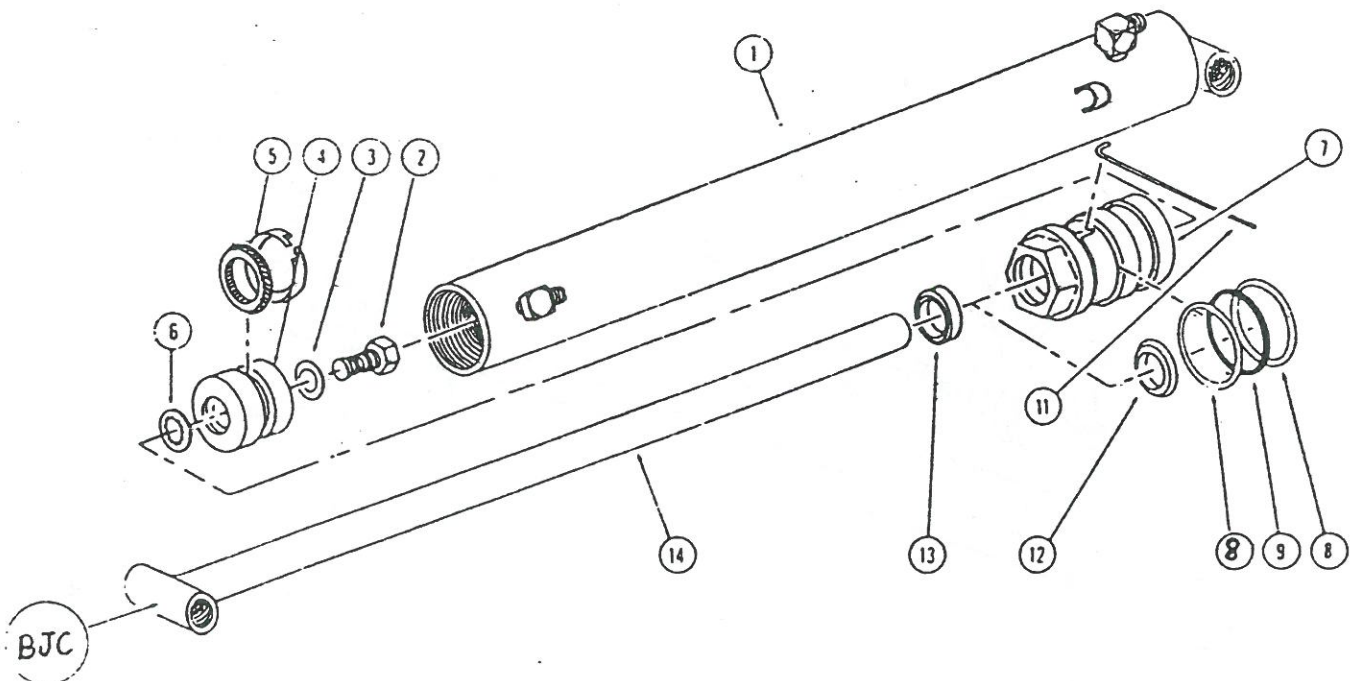

BCY11631 BUCKET CYLINDER, 2-1/2"x20"

Ill. No.	Qty.	Part No.	Description	Ill. No.	Qty.	Part No.	Description
1	1	SCY11729	Barrel Assembly	8*	2	SCY1070	Back-Up Ring
2	1	SBT1017	Capscrew, 7/8"	9*	1	SCY1024	O'Ring
3*	1	SCY1018	Dyna Seal, 7/8"	11*	1	SCY1036	Lockwire
4	1	SCY1020	Piston	12*	1	SCY1025	Rod Seal
5*	1	SCY1019	Piston Seal	13*	1	SCY1027	Rod Wiper
6*	1	SWS245	Internal Lockwasher	14	1	SCY10982	Rod Assembly

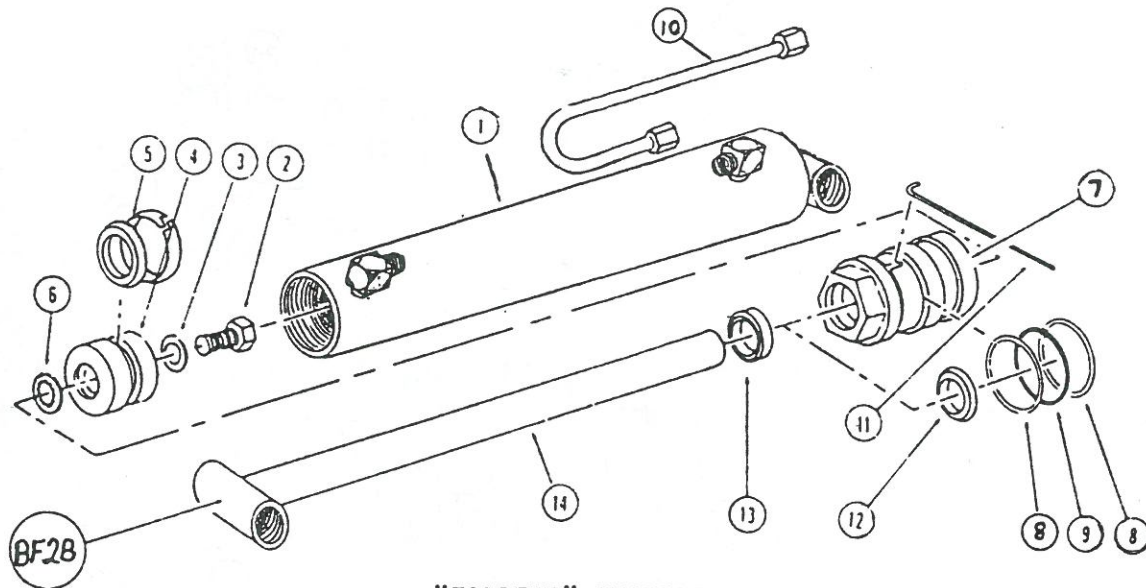

"FOLDING" STABILIZER

BCY11632 FOLDING AND GULL WING STABILIZER CYLINDER, 2-1/2"x13"
FOR MODEL B30FH & B30FJ

Ill. No.	Qty.	Part No.	Description	Ill. No.	Qty.	Part No.	Description
1	1	SCY11692	Barrel Assembly	8*	2	SCY1070	Back-Up Ring
2	1	SBT1017	Capscrew, 7/8"	9*	1	SCY1024	O'Ring
3*	1	SCY1018	Dyna Seal, 7/8"	10	1	BOL11728	Steel Oil Line
4	1	SCY1020	Piston	11*	1	SCY1036	Lockwire
5*	1	SCY1020	Piston Seal	12*	1	SCY1025	Rod Seal
6*	1	SWS245	Internal Lockwasher	13*	1	SCY1027	Rod Wiper
7	1	SCY1034	Cylinder Head	14	1	SCY10981	Rod Assembly
				*	1	SCY1030	Seal Kit

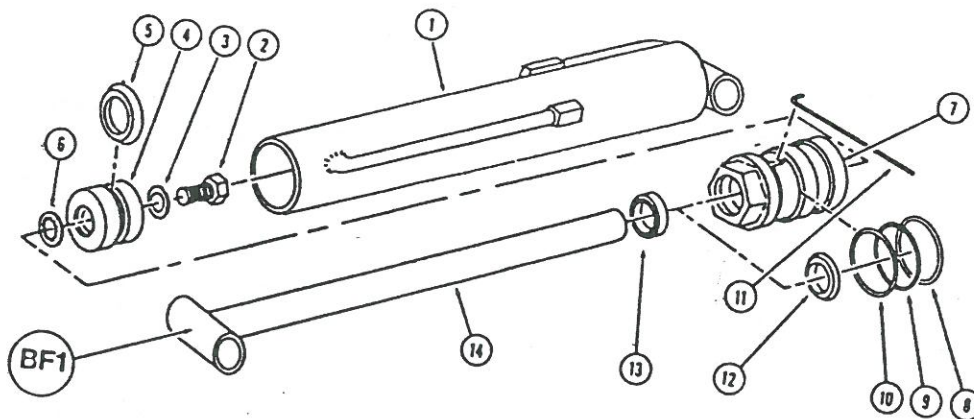

"SLANT DOWN" STABILIZER

BCY305 STABILIZER CYLINDER, 2"x16"

Ill. No.	Qty.	Part No.	Description	Ill. No.	Qty.	Part No.	Description
1	1	SCY1089	Barrel Assembly	8*	2	SCY10063	Back-Up Ring
2	1	SBT1017	Capscrew, 7/8"	9*	1	SCY1035	O'Ring
3*	1	SCY1018	Dyna Seal, 7/8"	11*	1	SCY1036	Lockwire
4	1	SCY1032	Piston	12*	1	SCY1025	Rod Seal
5*	1	SCY1031	Piston Seal	13*	1	SCY1027	Rod Wiper
6*	1	SWS245	Internal Lockwasher	14	1	SCY1088	Rod Assembly
7	1	SCY1034	Cylinder Head	*	1	SCY1038	Seal Kit

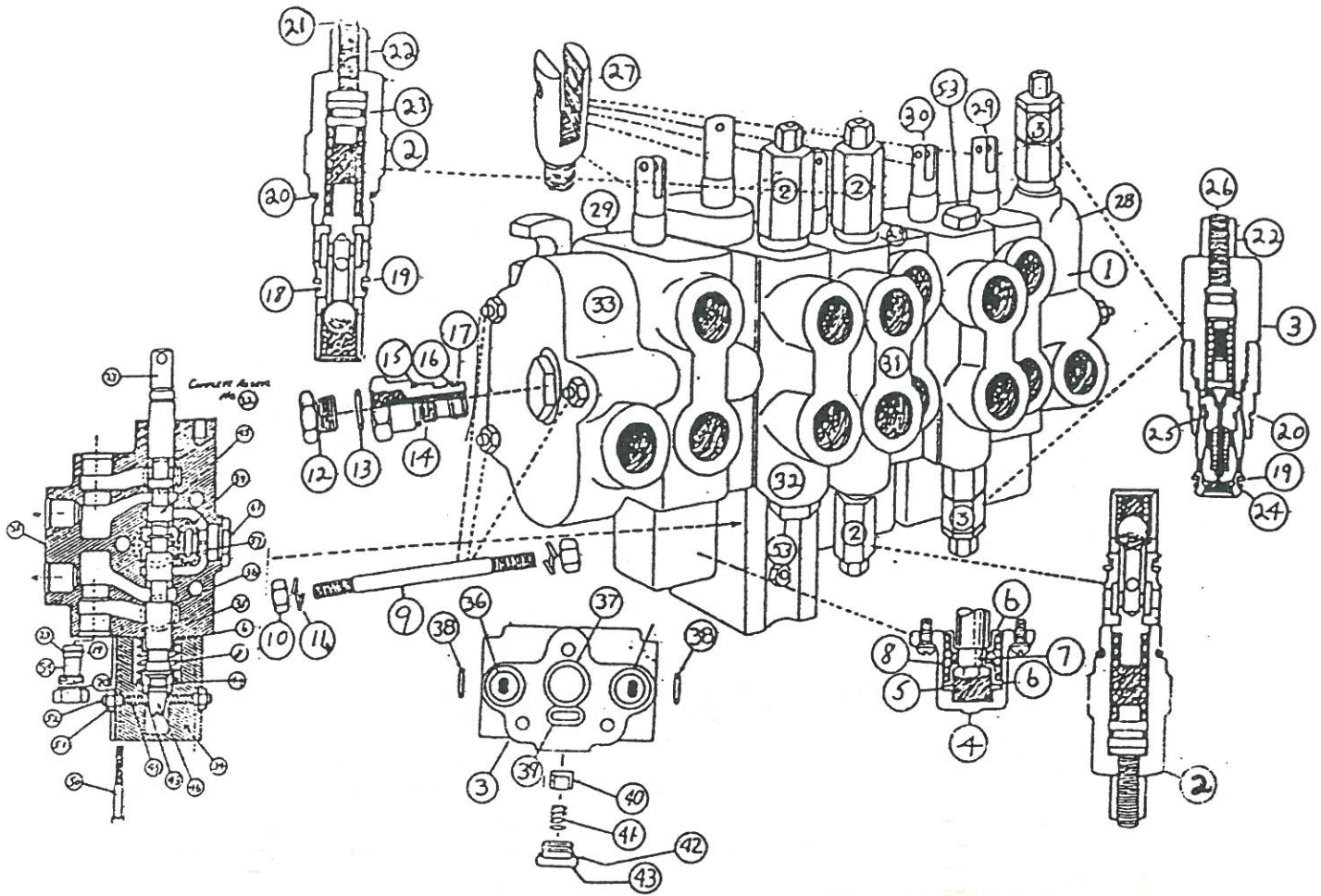

B30, B60 AND B70 HYDRAULIC VALVE

Ill. No.	Qty.	Part No.	Description	Ill. No.	Qty.	Part No.	Description
1	1	986757	Valve, Rexnord W/Float Spool	28	1	981113	Inlet Section
2	3	785197	Cartridge, Relief Anti-Cavitation	29	3	981100	L.H. And R.H. Stabilizer & Bucket
3	2	785057	Cartridge, Relief	30	1	980972	Stick Cylinder Section
4	6	254000	Cover	31	1	980973	Swing Section
5	6	255034	Spacer	32	1	981139	Boom Section W/Float Position
6	11	255013	Spring Retainer	33	1	980774	Outlet Section
7	6	255035	Spool End	34	1	254235	Lower Extension
8	6	410512	Spring	35	1	254241	Section Body
9	3	255162	Tie Rod	36	12	490308	O'Ring
10	6	401033	Tie Rod Nut	37	6	405895	O'Ring
11	6	400908	Tie Rod Lockwasher	38	12	401248	O'Ring
12	1	355098	Plug #10	39	6	406127	O'Ring
13	1	405393	O'Ring	40	6	255021	Load Check Piston
14	1	255049	Power Beyond Sleeve (OPTIONAL)	41	6	410520	Spring
15	1	405688	O'Ring (OPTIONAL)	42	6	405688	O'Ring
16	1	490975	Back-Up Ring (OPTIONAL)	43	8	255020	Plug
17	1	406460	O'Ring (OPTIONAL)	44	1	255258	Spring Retainer
18	3	404463	O'Ring	45	1	255257	Spool Assembly
19	5	490963	Back-Up Ring	46	1	255305	Spool End, Float
20	5	405393	O'Ring	47	1	785011	Load Check Assembly
21	3	410556	Adjustment Screw	48	2	401072	Ball, Detent
22	5	255271	Jam Nut	49	2	410560	Spring, Detent
23	3	401272	O'Ring	50	2	402964	Screw, Allen Head
24	2	406484	O'Ring	51	2	401032	Nut
25	2	407229	Seat, O'Ring	52	2	410540	Screw, Allen Head
26	2	410540	Adjustment Screw	53	2	785012	#8 SAE Plug (COMPLETE)
27	6	255002	Female Spool End	54	2	255033	#8 SAE Plug (ONLY)